

Micro Harmonics

Superior mm-Wave Components 25-400 GHz

Performance

Reliability

Collaboration

90-140 GHz Voltage Variable Attenuator



High-performance signal management

Micro Harmonics Corporation
Fincastle, VA 24090
+1 540.473.9983
sales@mhc1.com
microharmonics.com



Contact us



Introduction

Micro Harmonics specializes in the design and manufacture of advanced components, including Faraday rotation isolators, voltage variable attenuators, hybrid circulators, orthomode transducers, and cryogenic isolators. Our products cover every standard waveguide band from WR-28 (26-40 GHz) through WR-2.8 (260–400 GHz). All our products are fully guaranteed.

Why Choose Micro Harmonics Products?

Our products exhibit state-of-the-art performance in terms of low-insertion loss, broad-bandwidth, and the highest frequency coverage in the industry:

Lowest insertion loss

Full band test data

Direct engineering support

Our products are designed and manufactured in the United States. Many of our components were developed under the NASA SBIR program. Because of language in the congressional SBIR authorization, these products can be sole sourced for government acquisitions.

Our customers serve a variety of industries, including accelerator physics, fusion research, industrial automation, medical, metrology, radar, radio astronomy, remote sensing, satellite communications, telecommunications (5G networks), test and measurement, and other millimeter-wave systems.

Many companies are engineering our components into their systems and seeing improvements in system performance. Their systems are getting smaller and better. Join the growing number of engineers and scientists worldwide who are using our components to unlock the full potential of their mm-wave and terahertz systems.

Guarantee

No two mm-wave components have the same exact frequency response. Unique signatures arise from small misalignments and variations in the internal parts. The differences can be substantial. Max, Min, and typical specs are helpful, but what you need to see are the actual test data for the components you are buying. Micro Harmonics tests every component across the full waveguide band on a vector network analyzer. We supply the test data to the customer at no additional cost. Don't settle for anything less.

Table of Contents



Isulators

Page 3 - Faraday Rotation Isolators

26–400 GHz
WR-28 through WR-2.8
Full waveguide band



Attenuators

Page 8 - Voltage Variable Attenuators

75–170 GHz
WR-10, WR-8, WR-6.5
Full waveguide band



Circulators

Page 11 - Hybrid Circulators

50–330 GHz
WR-15 through WR-3.4
Broad & Full waveguide bands

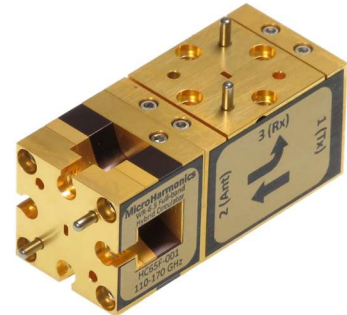

OMTs

Page 14 - Orthomode Transducers

50–400 GHz
WR-15, WR-8, WR-6.5
WR-5.1, WR-3.4, WR-2.8
Full waveguide band



Cryogenics

Page 17 - Cryogenic Components

26–220 GHz
WR-28 through WR-5.1
Full waveguide band



Page 18 - Appendices

Micro Harmonics offers a complete line of Faraday rotation isolators covering 25–400 GHz in every standard waveguide band from WR-28 through WR-2.8. These isolators exhibit state-of-the-art performance in terms of low insertion loss, high power handling, broad-bandwidth, and low port reflections. They are the most advanced isolators on the market today.

“The compact size, extremely low insertion loss, and the wide bandwidth have allowed us to use isolators in a wider variety of our systems than was previously possible and have led to significant improvements in key system performance metrics such as source power and sensitivity.”

*Jeffrey Hesler, Ph.D.
CTO, Virginia Diodes*

“They had an isolator with the single most important parameter I needed, low insertion loss. They were ultimately able to select one with just 1.2 dB loss at 240 GHz, which is pretty phenomenal.”

*Curt Dunnam, Director of Operations
ACERT National Biomedical Center at Cornell*

The graph below shows the insertion loss of our isolators as compared to other vendors. The insertion loss of our WR-3.4 isolator is only 2 dB! Don’t waste valuable mm-wave signal power by using an isolator with high insertion loss. Join the many companies who are using our isolators in their systems and seeing tangible improvements in system performance.

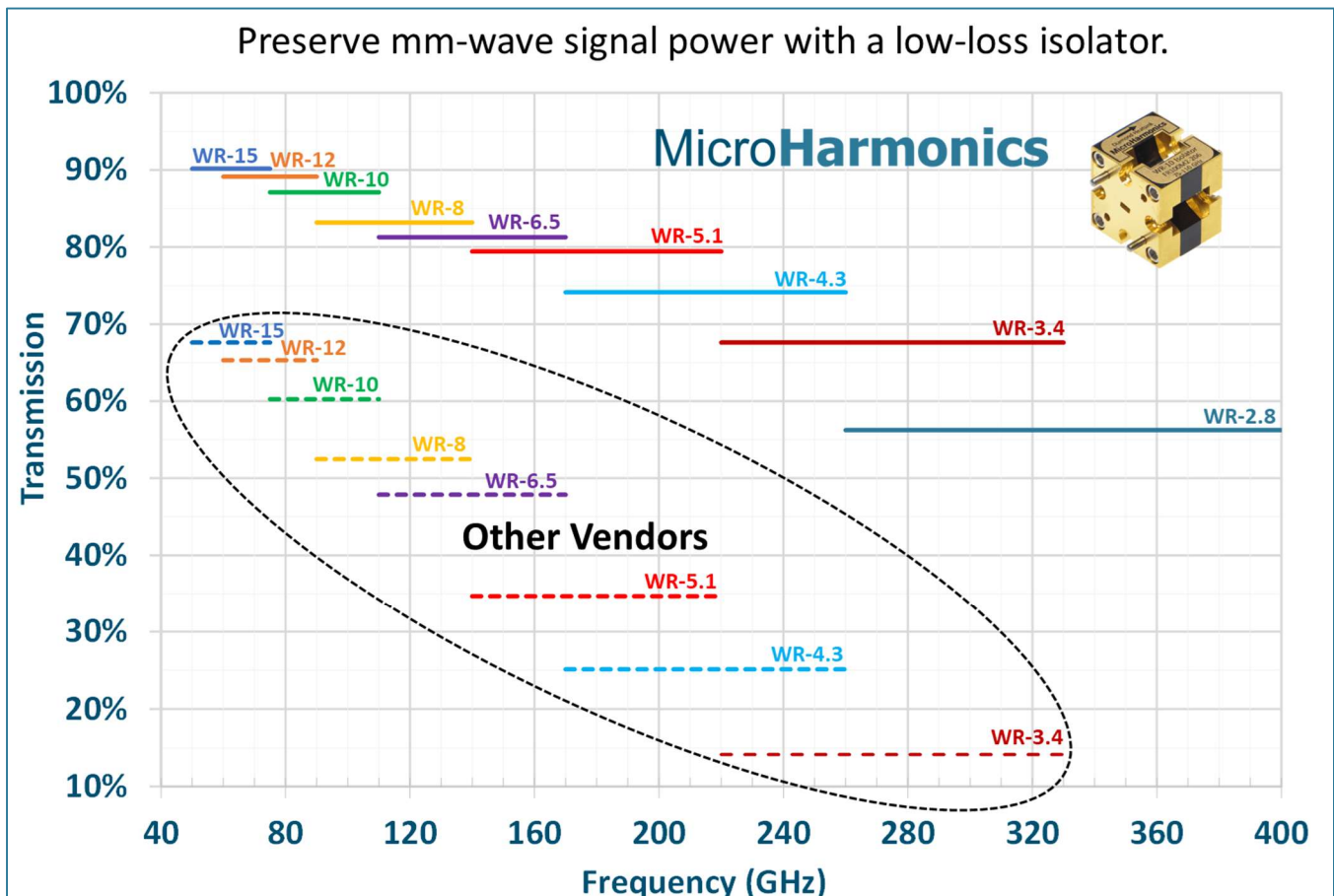

Faraday Rotation Isolators

| Model | Flange (EIA) | Band (GHz) | Insertion Loss (dB, avg) | Isolation (dB, typ min) | Max Power† (dBm W) | Status |
|-------|--------------|------------|--------------------------|-------------------------|----------------------|---------------|
| FR280 | WR-28 | 26–40 | 0.5 | 23 | 37 5.0 | Now available |
| FR188 | WR-19 | 40–60 | 0.5 | 20 | 36 4.3 | Now available |
| FR148 | WR-15 | 50–75 | 0.6 | 23 | 36 3.8 | Now available |
| FR122 | WR-12 | 60–90 | 0.5 | 20 | 35 3.5 | Now available |
| FR100 | WR-10 | 75–110 | 0.6 | 25 | 35 2.9 | Now available |
| FR090 | WR-9 | 82–122 | 0.9 | 21 | 34 2.7 | Now available |
| FR080 | WR-8 | 90–140 | 0.8 | 24 | 34 2.4 | Now available |
| FR065 | WR-6.5 | 110–170 | 0.8 | 25 | 33 1.9 | Now available |
| FR051 | WR-5.1 | 140–220 | 1.1 | 22 | 31 1.3 | Now available |
| FR043 | WR-4.3 | 170–260 | 1.3 | 22 | 30 1.0 | Now available |
| FR034 | WR-3.4 | 220–330 | 1.8 | 23 | 28 0.6 | Now available |
| FR028 | WR-2.8 | 260–400 | 2.7 | 21 | 26 0.4 | Now available |

† See page 7.



Isolator webpage

Distinctives

- Lowest insertion loss
- Highest power rating
- Full band test data
- Direct engineering support

Applications

- Impedance matching
- Protection from reflected power
- Measurement & instrumentation
- Sub-assemblies
- Laboratory measurement & test equipment
- Broadband systems

Model: FR065

Specifications

| | |
|--------------------------|---------------------|
| Flange | WR-6.5 UG-387/UM |
| Frequency (GHz) | 110-170 |
| Insertion Loss (dB, avg) | 0.8 |
| Insertion Loss (dB, max) | 1.8 |
| Isolation (dB, typ min) | 25 |
| Input RL (dB, typ min) | 16 |
| Output RL (dB, typ min) | 17 |
| VSWR (typ max) | 1.4:1 |
| Maximum Power (W) | 1.9 |
| Diamond Heatsink | Yes |
| Weight (Oz [g]) | 0.50 [14] |

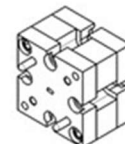
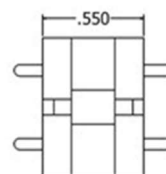
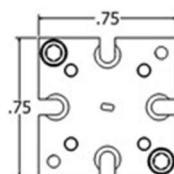
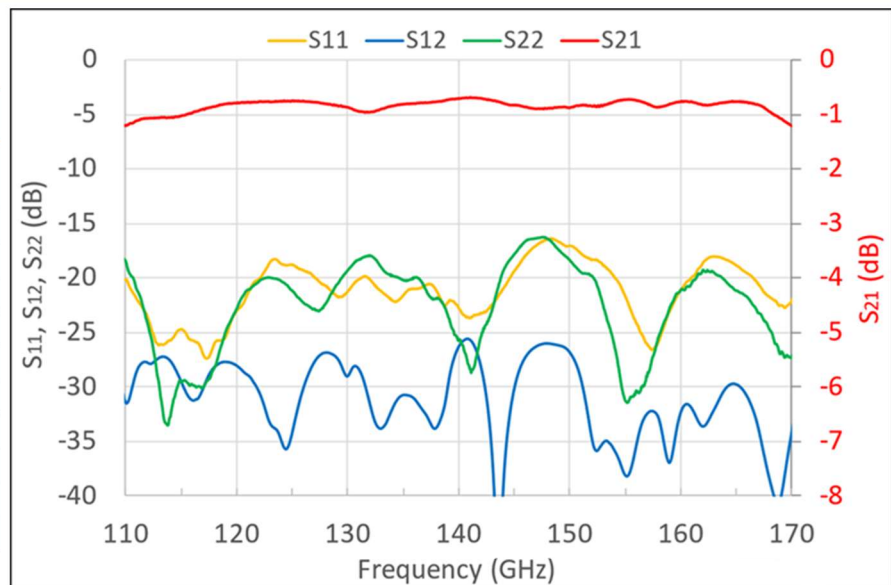

Faraday Rotation Isolators – Sample Test Data

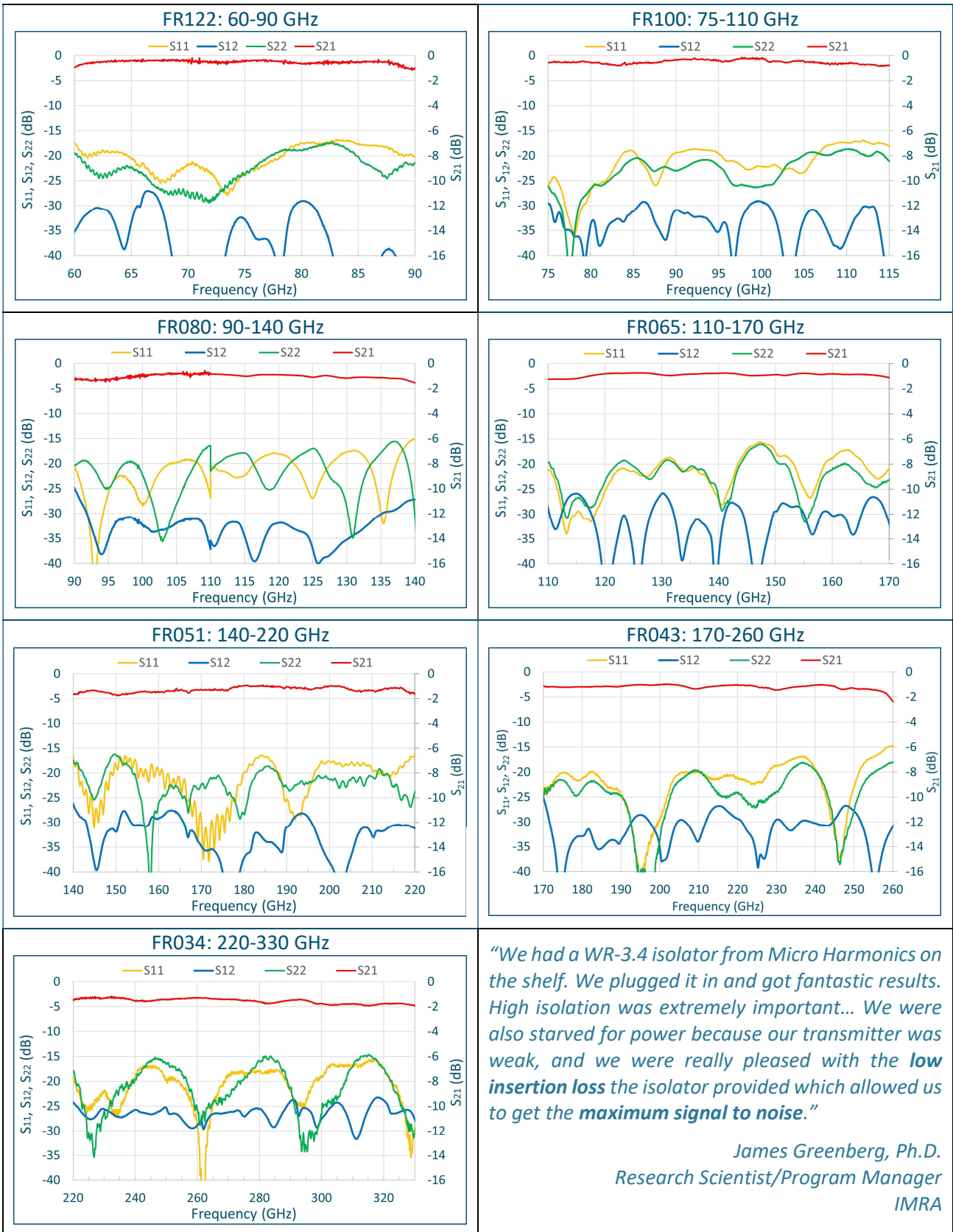

*“We had a WR-3.4 isolator from Micro Harmonics on the shelf. We plugged it in and got fantastic results. High isolation was extremely important... We were also starved for power because our transmitter was weak, and we were really pleased with the **low insertion loss** the isolator provided which allowed us to get the **maximum signal to noise.**”*

*James Greenberg, Ph.D.
Research Scientist/Program Manager
IMRA*

Faraday Rotation Isolators

Isolator Power Ratings—In a Faraday rotation isolator, reverse power is absorbed in a resistive layer and converted to heat energy. In isolators sold by other vendors, the resistive layer can get hot because it is thermally isolated. But Micro Harmonics isolators employ a diamond disc that provides an excellent path to conduct heat from the resistive layer to the metal block. The graph below shows the maximum reverse power ratings of our isolators and the average of other vendors. The Micro Harmonics power ratings are conservative to ensure low temperatures and long life.

Highest power rating

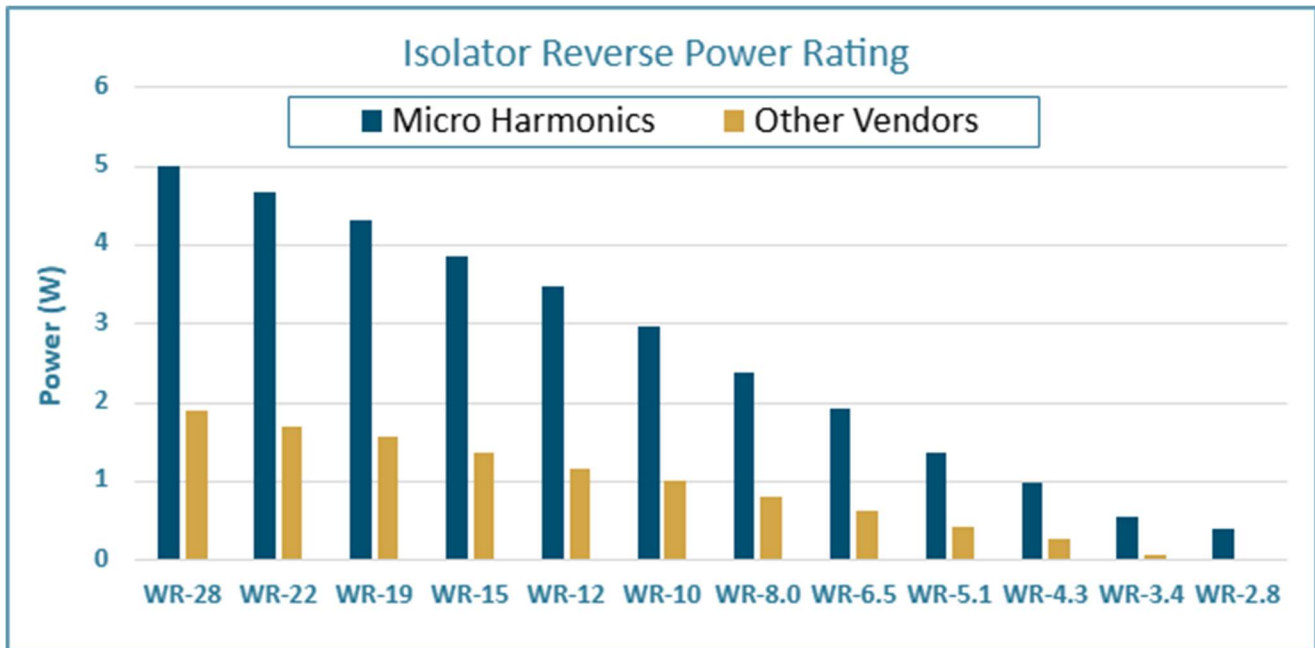

Micro Harmonics Isolators are Insensitive to Stray Magnetic Fields

Have you seen the label on other isolators warning you to keep them away from magnetic fields? You will not find that label on a Micro Harmonics isolator because our isolators are highly resistant to external magnetic fields. Other isolators use a highly tuned magnetic field that is easily perturbed by even a small external magnetic field. This causes under- or over-rotation of the signal and severe performance degradation. Micro Harmonics isolators use a highly saturated magnetic bias field which makes them insensitive to stray magnetic fields. The phenomenon is explained in more detail in an article published in the April 2021 edition of the Microwave Journal.



[Microwave Journal article on stray magnetic fields](#)

We design and manufacture all our products in the United States. Every component is thoroughly RF tested, and the data for each individual component is shared with the customer. We use anti-cocking waveguide flanges. All our products are fully guaranteed.

| Model | Flange (EIA) | Band (GHz) | Dynamic Range (dB, Min) | Insertion Loss (dB, Avg) | Max Power (dBm W) | Status |
|-------|--------------|------------|-------------------------|--------------------------|---------------------|-------------------|
| VA148 | WR-15 | 50–75 | | | | Under development |
| VA122 | WR-12 | 60–90 | | | | Under development |
| VA100 | WR-10 | 75–110 | 0–35 | 1.2 | 34 2.3 | Now available |
| VA080 | WR-8 | 90–140 | 0–30 | 0.8 | 34 2.4 | Now available |
| VA065 | WR-6.5 | 110–170 | 0–35 | 1.5 | 32 1.5 | Now available |
| VA051 | WR-5.1 | 140–220 | | | | Under development |
| VA043 | WR-4.3 | 170–260 | | | | Under development |
| VA034 | WR-3.4 | 220–325 | | | | Under development |

Distinctives

- Lowest insertion loss
- Electrically controllable
- No moving parts
- Not ESD sensitive
- Full band
- Smallest form factor
- Full band test data
- Direct engineering support

Applications

- Equalization
- Calibration
- Switching
- Power control
- Power sweeps
- Power characterization
- Test equipment
- Instrumentation
- Test setups

Our attenuators use Faraday rotation in a ferrite rod to rotate an RF signal into a fixed resistive vane. The attenuation level is set using a simple DC voltage in the range from 0–10 V. They are configured so that maximum attenuation is achieved at 0 V bias.



WR-6.5 attenuator

The attenuator is compact, lightweight, and has no moving parts. The small size makes the attenuator very easy to fit into millimeter-wave systems. The technology is passive and insensitive to ESD damage. Our attenuators can handle significantly higher power levels than PIN attenuators.



[Attenuator page](#)

Voltage Variable Attenuators

Measured data from our D-band WR-6.5 attenuator is shown below. The dynamic range is more than 35 dB. The WR-6.5 attenuator has a power rating of 1.5 W.

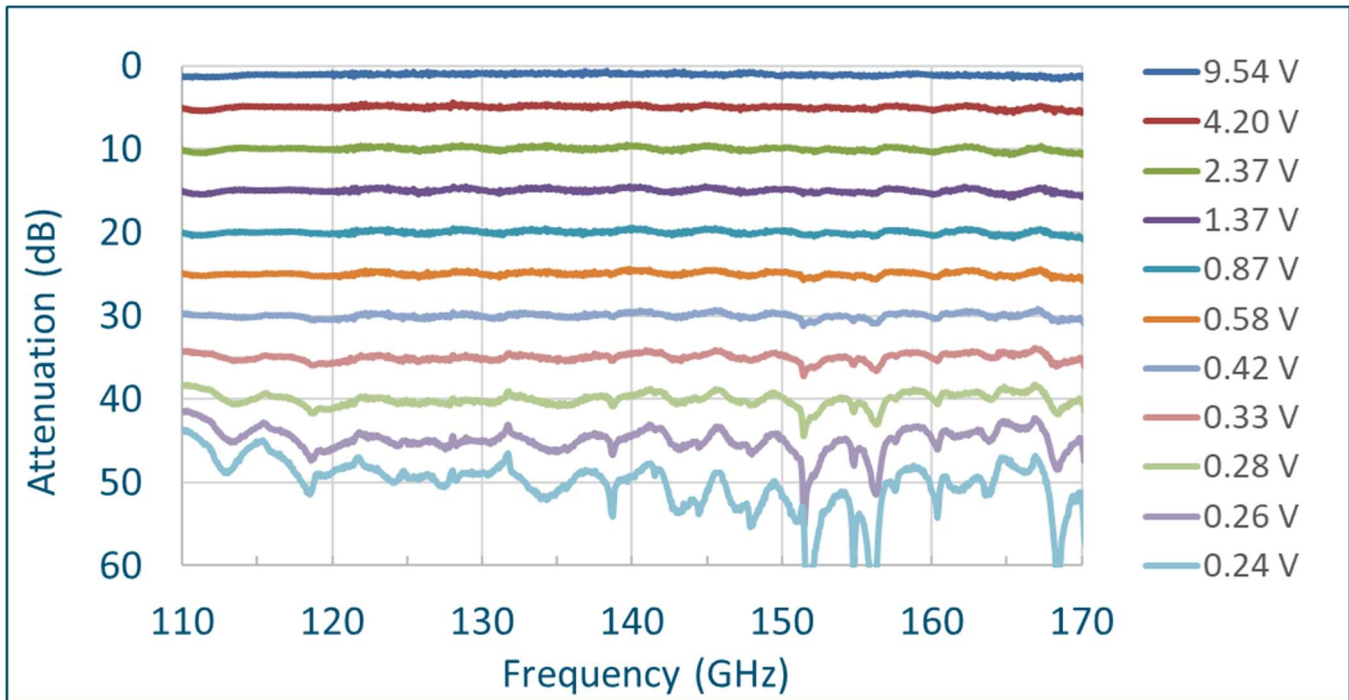

An important advantage of the ferrite attenuator is the relatively low port reflections. The graph below shows measured reflections on Port 1 at the various attenuation levels of the WR-6.5 attenuator. The reflections are less than -14 dB across the band for every attenuation level. This compares favorably to the port reflections found on PIN attenuators which can approach -5 dB.

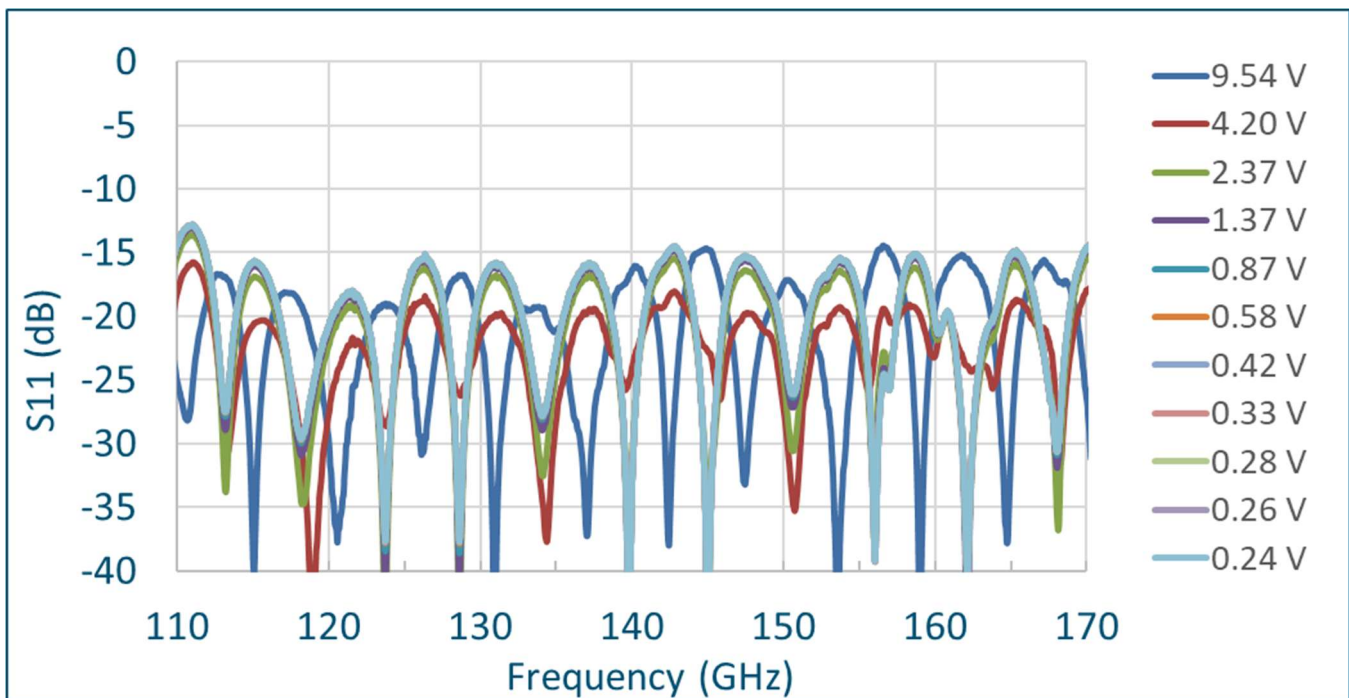

Our variable attenuators have short rise and fall times, have no moving parts, and are electrically controlled. This enables reliable and repeatable point-by-point tuning and control at 1-5 ms per point. For high dynamic range and high flatness applications, the variable attenuator can be flattened out with point-by-point voltage control. Below is an example of an F-band variable attenuator at about 25 dB attenuation. The gold line represents attenuation with a DC bias, and the blue line represents flattened attenuation with point-by-point tuning.

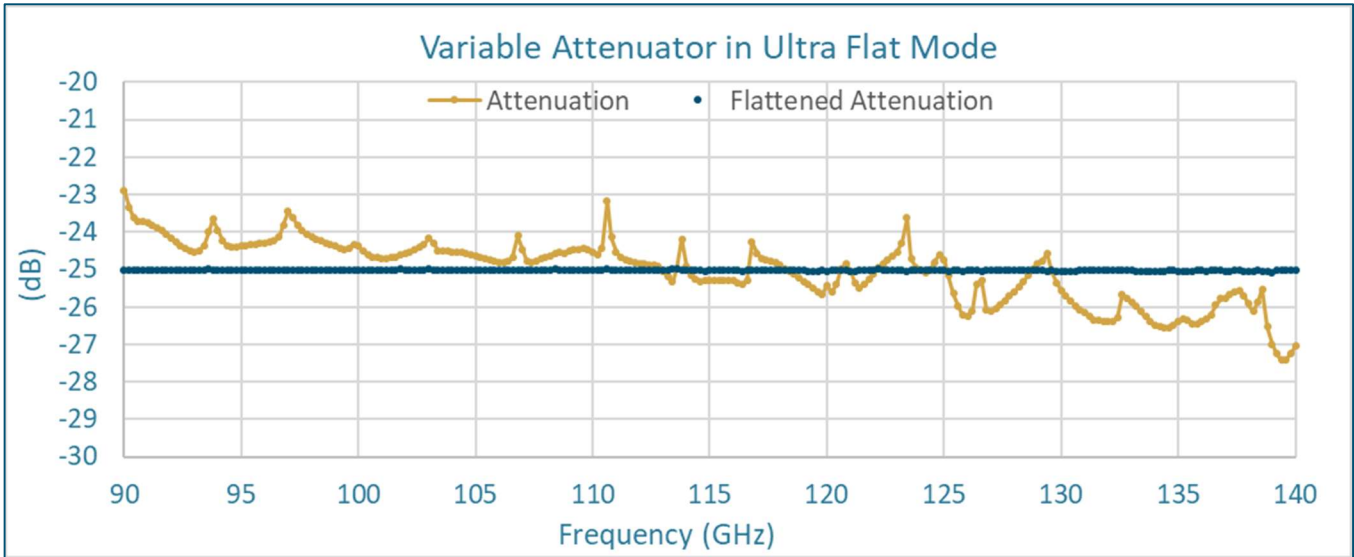

Point-by-point tuning also enables equalization of an external source. This concept is demonstrated below by equalizing a signal varying 10 dB across the WR-8 band (represented by the gold line). The variable attenuator has been used as an equalizer to flatten this signal (represented by the blue line).

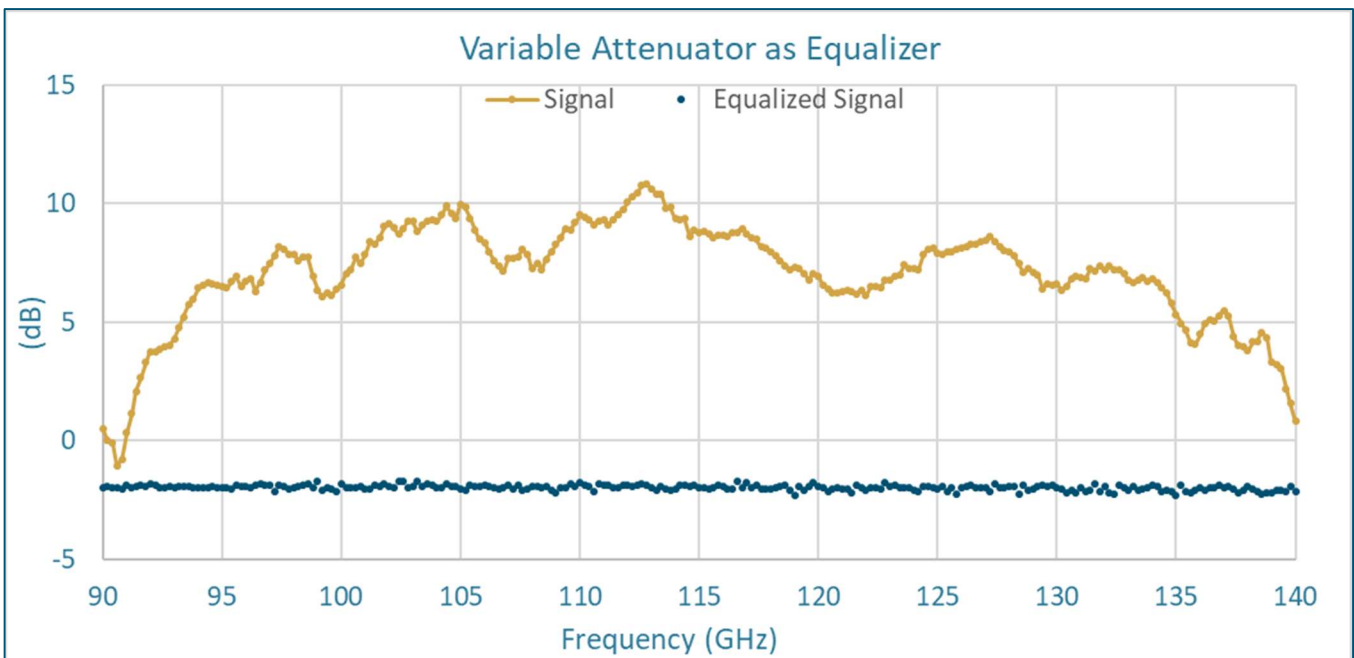

| Flange (EIA) | Model (24%) | Frequency (GHz) | Model (24%) | Frequency (GHz) |
|--------------|-------------|-----------------|-------------|-----------------|
| WR-15 | HC148 | 54–68 | HC148F | 50–75 |
| WR-12 | HC122 | 70–86 | HC122F | 60–90 |
| WR-10 | HC100 | 85–104 | HC100F | 75–110 |
| WR-8 | HC080 | 107–133 | HC080F | 90–140 |
| WR-6.5 | HC065 | 118–150 | HC065F | 110–170 |
| WR-5.1 | HC051 | 150–190 | HC051F | 140–220 |
| WR-4.3 | HC043 | 196–250 | HC043F | 170–260 |
| WR-3.4 | HC034 | 258–330 | HC034F | 220–330 |

Blue: Models currently available Gold: Models under development



Circulators

Distinctives

- Broadband
- Frequency coverage 50-330 GHz
- Lowest insertion loss
- Full band test data
- Direct engineering support

Applications

- Transmit/receive systems
- 6G communication systems
- Radiometers
- Satellite data transmission
- Satellite television broadcasting
- Military radar systems
- Telecommunication
- Monostatic radar

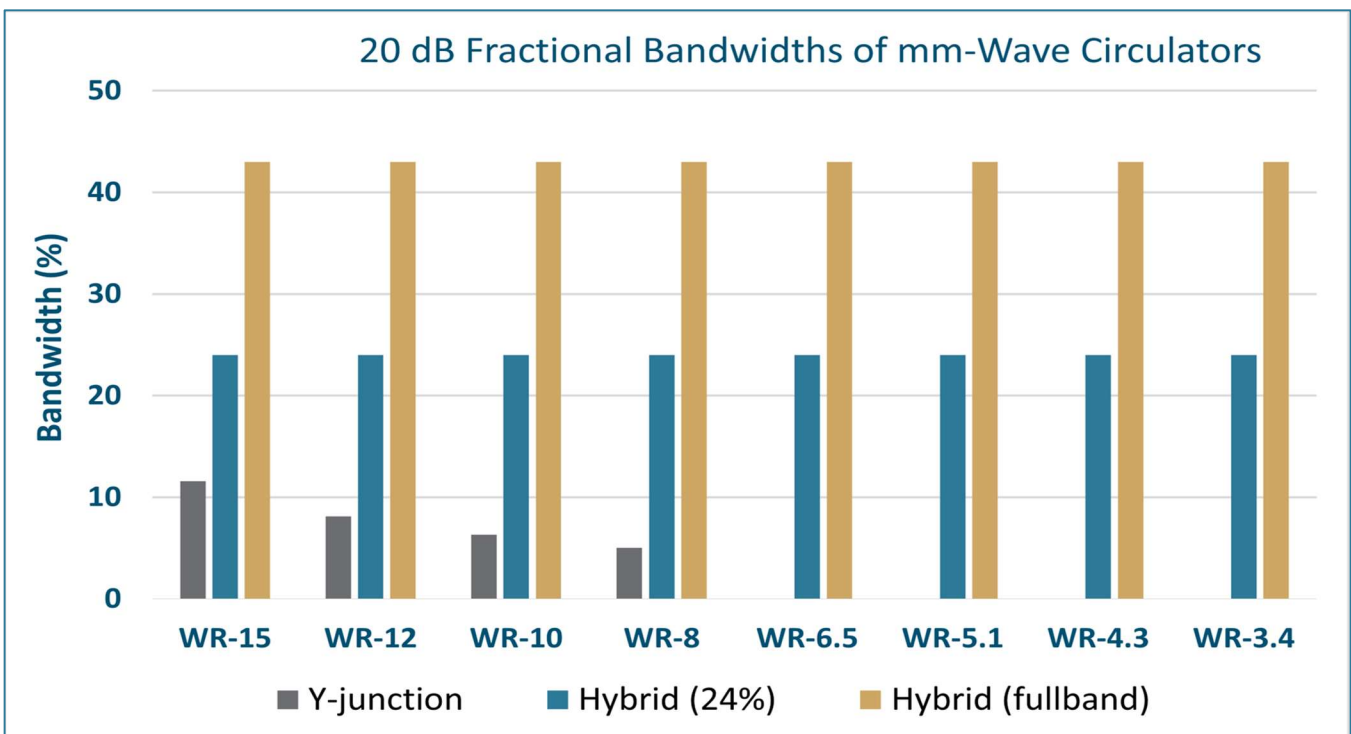

Hybrid Circulators

The hybrid circulator comprises a Faraday rotator and an orthomode transducer (OMT). Since both the Faraday rotator and OMT are inherently broadband, the hybrid circulator is also broadband.

Measured RF test data for the full band WR-6.5 hybrid circulator are shown in the graph below. Isolation is greater than 20 dB. Return loss is greater than 15 dB. Insertion loss is less than 1.5 dB across most of the band. This level of performance has never been achieved before in a D-band circulator.

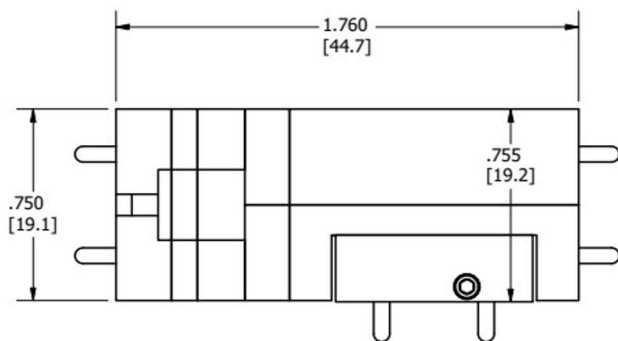
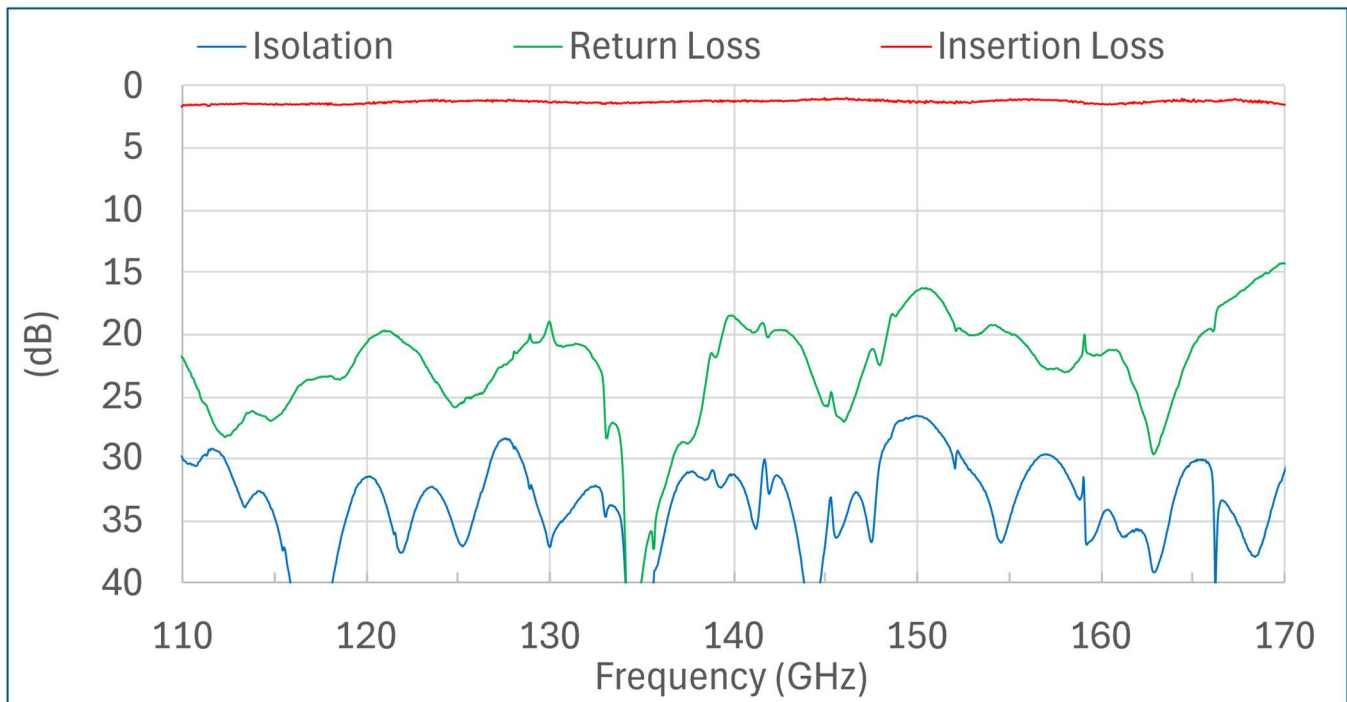

HC065F
WR-6.5
(> 40%)

The patented hybrid circulator technology is only available from Micro Harmonics. Please contact us for more information.

High Isolation Hybrid Circulators

In high-power transceiver systems, the sensitive receiver (Rx) must be isolated from the high-power transmitter (Tx) signal. The 20 dB isolation provided by Y-junction circulators is insufficient. Circulators employing multiple Y-junctions can achieve some increased isolation parameters, but the isolation of the receiver from the transmitter signal cannot be increased by using multiple junctions.

To understand why, consider the schematic for a triple junction circulator. The three circulators are designated “A”, “B”, and “C”. Circulators “A” and “C” function as isolators since their third ports are terminated with matched loads. A single isolation path on circulator “B”, $|S_{31}|$, blocks the transmit signal from reaching the receiver. Regardless of how many junctions are used, a multi-Y-junction circulator can only have a single isolation path protecting the receiver (Rx) from the transmitter (Tx).

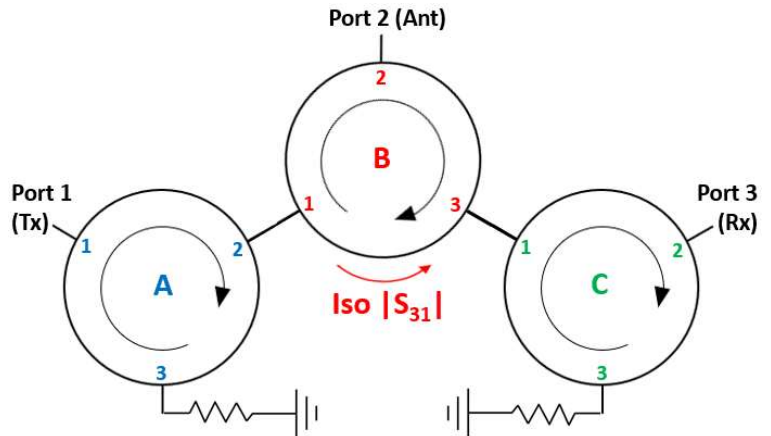

But Micro Harmonics’ unique hybrid circulators can be designed to achieve high S_{31} isolation over broad bandwidths. HFSS simulation data are shown below for a hybrid circulator with S_{31} isolation of more than 40 dB over the band 157–162 GHz. Measured data from a Y-junction are shown for comparison. High isolation hybrid circulators can be designed up to 330 GHz.

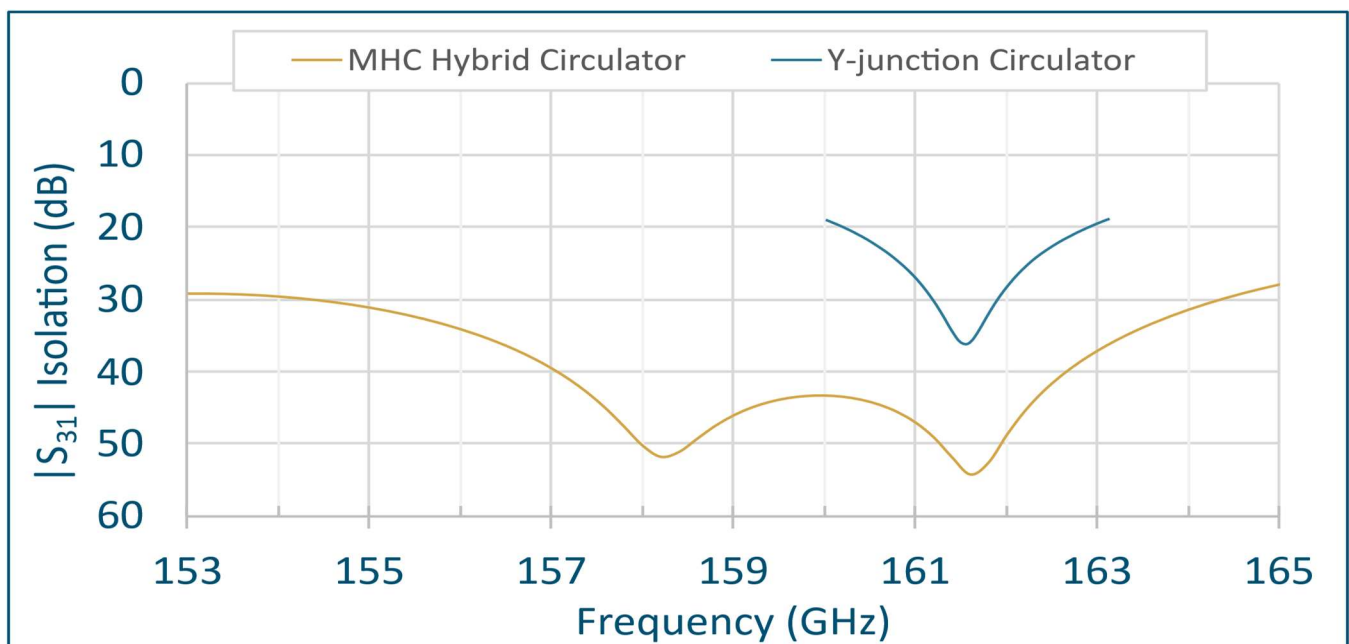

Our orthomode transducers (OMTs) cover full waveguide bands. They have low insertion loss, low cross-polarization coupling, and high isolation. OMTs are now available in WR-15, WR-8, WR-6.5, WR-5.1, WR-3.4, and WR-2.8. Additional OMTs are in various stages of development as indicated in the table.



OMTs

| Model | Band | Frequency (GHz) | Status |
|-------|--------|-----------------|-------------------|
| OT148 | WR-15 | 50–75 | Now available |
| OT122 | WR-12 | 60–90 | Under development |
| OT100 | WR-10 | 75–110 | Under development |
| OT080 | WR-8 | 90–140 | Now available |
| OT065 | WR-6.5 | 110–170 | Now available |
| OT051 | WR-5.1 | 140–220 | Now available |
| OT043 | WR-4.3 | 170–260 | Under development |
| OT034 | WR-3.4 | 220–330 | Now available |
| OT028 | WR-2.8 | 280–400 | Now available |
| OT022 | WR-2.2 | 330–500 | Future R&D effort |
| OT019 | WR-1.9 | 400–600 | Future R&D effort |
| OT015 | WR-1.5 | 500–750 | Future R&D effort |

Distinctives

- Lowest insertion loss
- Lowest cross-polarization coupling
- Highest isolation
- 50-400 GHz
- Full band test data
- Direct engineering support

Applications

- 6G Communication systems
- Radiometers
- Satellite data transmission
- Satellite television Broadcasting
- Military radar systems
- Telecommunication
- Dual polarization transmission



Orthomode Transducers

The graph below shows measured RF test data from our WR-3.4 OMT. Insertion loss is less than 0.8 dB across the band 220-330 GHz. The cross-polarization coupling is less than -38 dB. (We show the cross-pol coupling as a positive value to fit on the graph.) Isolation is at the 50 dB level. The return loss is greater than 18 dB.

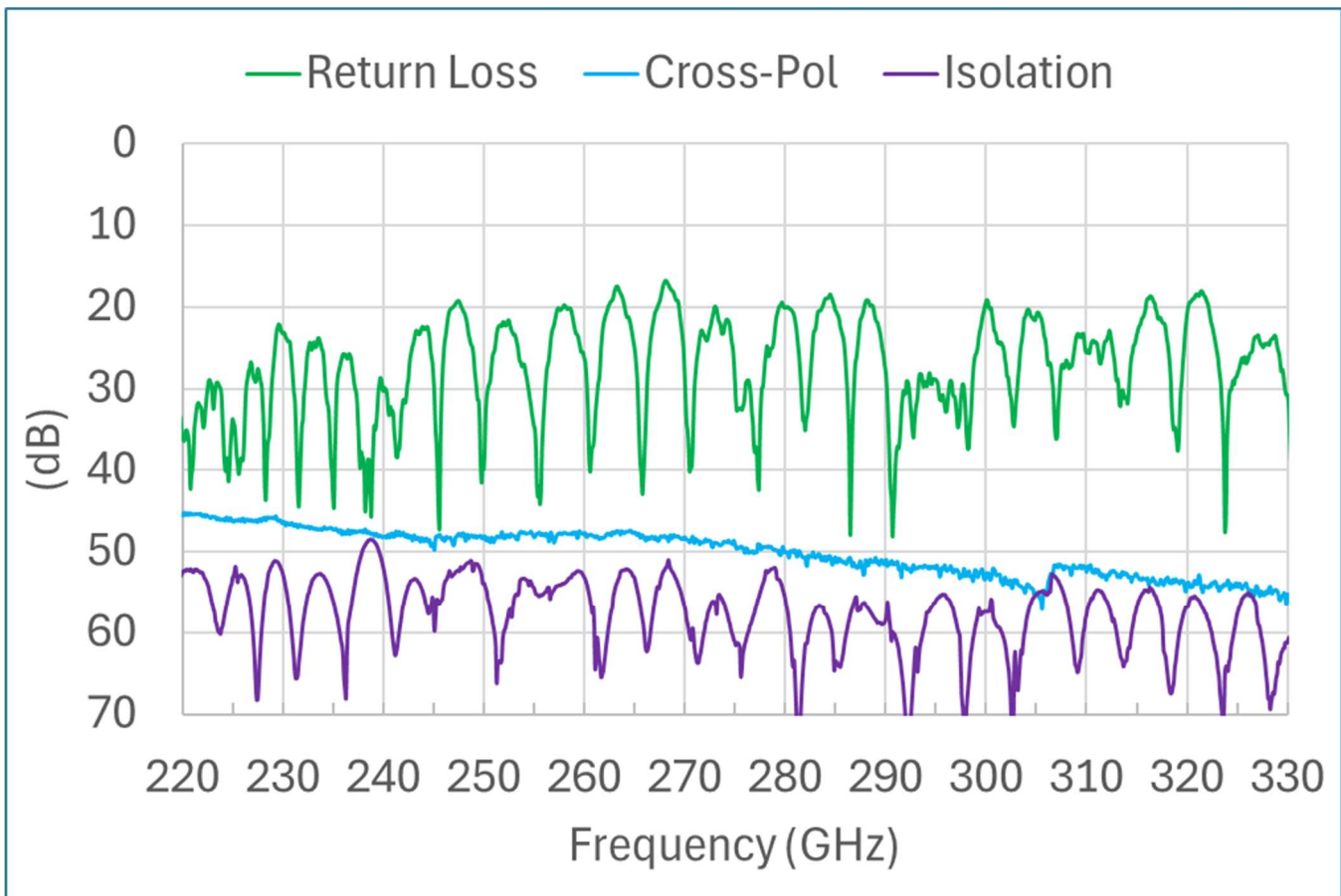
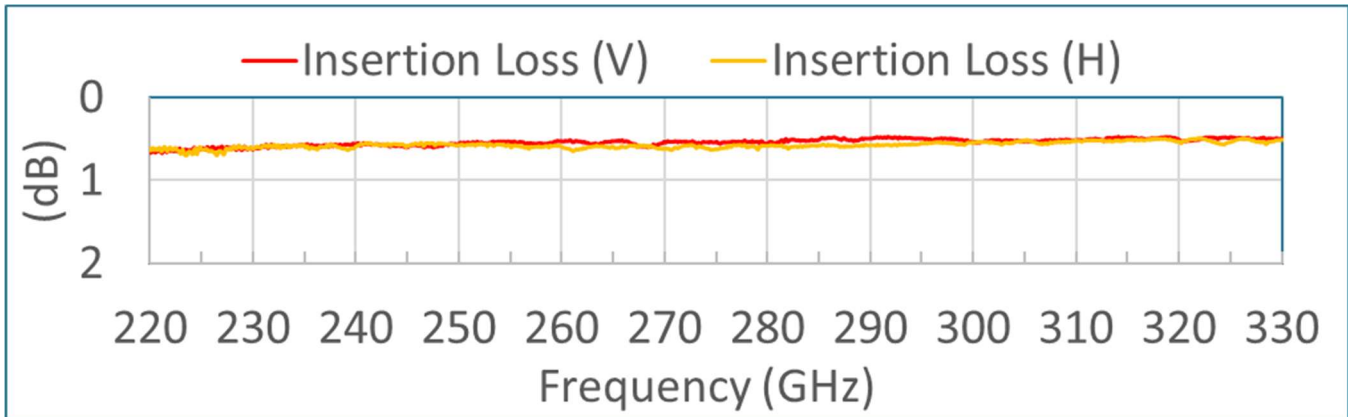

It is a common misconception that isolators designed to work at room temperature will work reasonably well at cryogenic temperatures. The problem is that the ferrite materials have a strong temperature dependence that impacts signal rotation. This can cause significant over-rotation of the signal and severely degrade performance at cryogenic temperatures.

“We tried using regular isolators from one vendor. We cooled them down and assumed they would work, but they weren’t behaving right.”

*Alexander Anferov, GRA
Shuster Lab, University of Chicago*

“We can get down to less than 100 Kelvins with commercially available cryo-coolers...Our biggest challenge was finding an isolator that could perform at those temps. Fortunately for us, a company called Micro Harmonics had just designed some specifically for NASA.”

*Dana Wheeler, President
Aerowave, Inc.*

At Micro Harmonics, we have developed a line of isolators designed for optimal performance at cryogenic temperatures. Reliability is verified through repeated thermal cycling in a liquid nitrogen bath. Our isolators are built to withstand the rigors of repeated cryogenic cycling.

Our cryogenic isolators are routinely tested at 25 K in our cryostat. We use a resistive thin film for isolation that is not in the class of super conductors. The performance has been independently verified down to 1 K by researchers at the University of Chicago and at the Smithsonian Astrophysical Observatory.

Distinctives

- Optimized for cryogenic conditions
- Lowest insertion loss
- Full band test data
- Direct engineering support

Applications

- Quantum research
- Radio astronomy
- Satellite communications & aerospace
- Defense and radar
- Medical and passive imaging



Cryogenic
Components

| Model | Flange | Band (GHz) | Insertion Loss (dB, typ @ 25 K) | Isolation (dB, typ @ 25 K) |
|--------|--------|------------|---------------------------------|----------------------------|
| FR280C | WR-28 | 26–40 | 0.5 | 25 |
| FR148C | WR-15 | 50–75 | 0.5 | 28 |
| FR122C | WR-12 | 60–90 | 0.7 | 25 |
| FR100C | WR-10 | 75–110 | 0.5 | 30 |
| FR090C | WR-9 | 82–122 | 0.5 | 30 |
| FR080C | WR-8 | 90–140 | 0.7 | 27 |
| FR065C | WR-6.5 | 110–170 | 0.9 | 23 |
| FR051C | WR-5.1 | 140–220 | 1.2 | 23 |

Cryogenic Components

Model: FR100C

| Specifications | |
|---|-------------------|
| Flange | WR-10 UG387/UM |
| Frequency (GHz) | 75-110 |
| Insertion Loss (dB, avg) @ 25K @ Room Temperature | 0.5 0.6 |
| Isolation (dB, typ min) @ 25K @ Room Temperature | 24 17 |
| Input RL (dB, typ min) | 18 |
| Output RL (dB, typ min) | 18 |
| VSWR (typ max) | 1.3:1 |
| Maximum Power (W) | 1.0 |

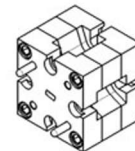
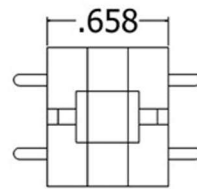
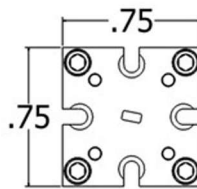
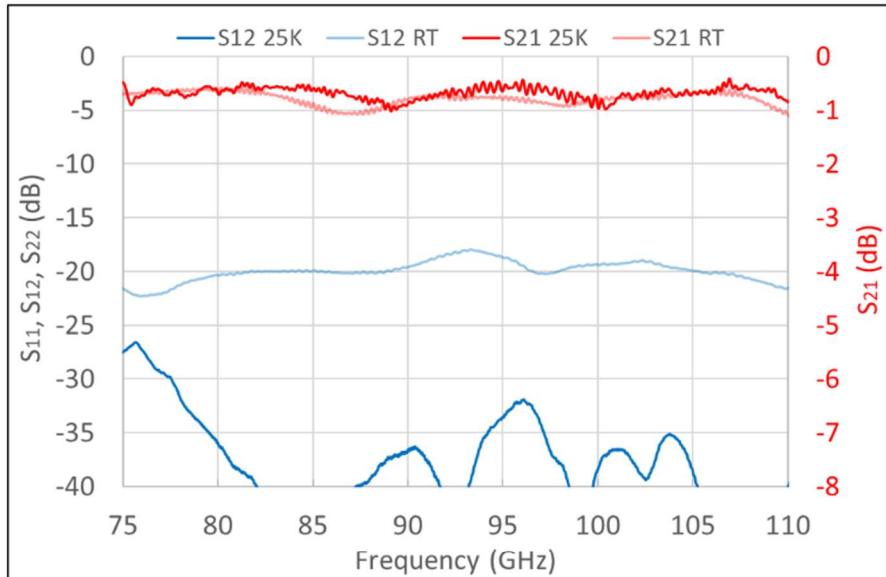
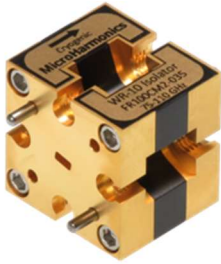

Cryogenic Hybrid Circulator

Part of our mission is to “serve our customers through the advancement of mm-wave component technology.” So when in 2024 a customer requested a WR-10 cryogenic circulator, we united our expertise in cryogenic isolators and our patented hybrid circulators to produce a WR-10 cryogenic hybrid circulator within only two weeks.

We continue to listen to market needs and are always looking for more ways to satisfy every customer.

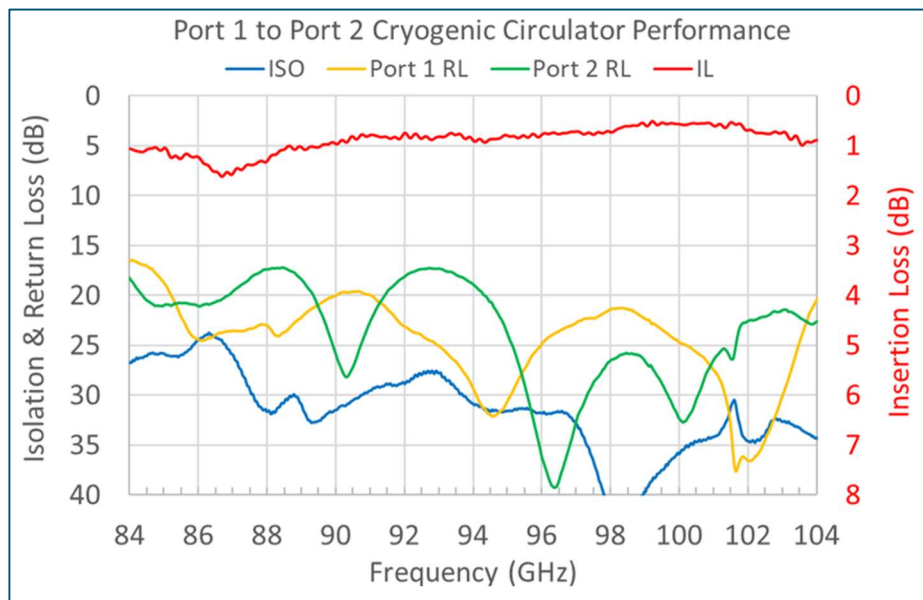

Insertion Loss –vs- Transmission Conversion Table

| IL (dB) | T (%) | IL (dB) | T (%) | IL (dB) | T (%) | IL (dB) | T (%) | IL (dB) | T (%) | IL (dB) | T (%) |
|---------|--------|---------|-------|---------|-------|---------|-------|---------|-------|---------|----------|
| 0.0 | 100.00 | 2.0 | 63.10 | 4.0 | 39.81 | 6.0 | 25.12 | 8.0 | 15.85 | 10.0 | 10.00 |
| 0.1 | 97.72 | 2.1 | 61.66 | 4.1 | 38.90 | 6.1 | 24.55 | 8.1 | 15.49 | 10.1 | 9.77 |
| 0.2 | 95.50 | 2.2 | 60.26 | 4.2 | 38.02 | 6.2 | 23.99 | 8.2 | 15.14 | 10.2 | 9.55 |
| 0.3 | 93.33 | 2.3 | 58.88 | 4.3 | 37.15 | 6.3 | 23.44 | 8.3 | 14.79 | 10.3 | 9.33 |
| 0.4 | 91.20 | 2.4 | 57.54 | 4.4 | 36.31 | 6.4 | 22.91 | 8.4 | 14.45 | 10.4 | 9.12 |
| 0.5 | 89.13 | 2.5 | 56.23 | 4.5 | 35.48 | 6.5 | 22.39 | 8.5 | 14.13 | 10.5 | 8.91 |
| 0.6 | 87.10 | 2.6 | 54.95 | 4.6 | 34.67 | 6.6 | 21.88 | 8.6 | 13.80 | 10.6 | 8.71 |
| 0.7 | 85.11 | 2.7 | 53.70 | 4.7 | 33.88 | 6.7 | 21.38 | 8.7 | 13.49 | 10.7 | 8.51 |
| 0.8 | 83.18 | 2.8 | 52.48 | 4.8 | 33.11 | 6.8 | 20.89 | 8.8 | 13.18 | 10.8 | 8.32 |
| 0.9 | 81.28 | 2.9 | 51.29 | 4.9 | 32.36 | 6.9 | 20.42 | 8.9 | 12.88 | 10.9 | 8.13 |
| 1.0 | 79.43 | 3.0 | 50.12 | 5.0 | 31.62 | 7.0 | 19.95 | 9.0 | 12.59 | | |
| 1.1 | 77.62 | 3.1 | 48.98 | 5.1 | 30.90 | 7.1 | 19.50 | 9.1 | 12.30 | 0 | 100 |
| 1.2 | 75.86 | 3.2 | 47.86 | 5.2 | 30.20 | 7.2 | 19.05 | 9.2 | 12.02 | 10 | 10 |
| 1.3 | 74.13 | 3.3 | 46.77 | 5.3 | 29.51 | 7.3 | 18.62 | 9.3 | 11.75 | 20 | 1 |
| 1.4 | 72.44 | 3.4 | 45.71 | 5.4 | 28.84 | 7.4 | 18.20 | 9.4 | 11.48 | 30 | 0.1 |
| 1.5 | 70.79 | 3.5 | 44.67 | 5.5 | 28.18 | 7.5 | 17.78 | 9.5 | 11.22 | 40 | 0.01 |
| 1.6 | 69.18 | 3.6 | 43.65 | 5.6 | 27.54 | 7.6 | 17.38 | 9.6 | 10.96 | 50 | 0.001 |
| 1.7 | 67.61 | 3.7 | 42.66 | 5.7 | 26.92 | 7.7 | 16.98 | 9.7 | 10.72 | 60 | 0.0001 |
| 1.8 | 66.07 | 3.8 | 41.69 | 5.8 | 26.30 | 7.8 | 16.60 | 9.8 | 10.47 | 70 | 0.00001 |
| 1.9 | 64.57 | 3.9 | 40.74 | 5.9 | 25.70 | 7.9 | 16.22 | 9.9 | 10.23 | 80 | 0.000001 |

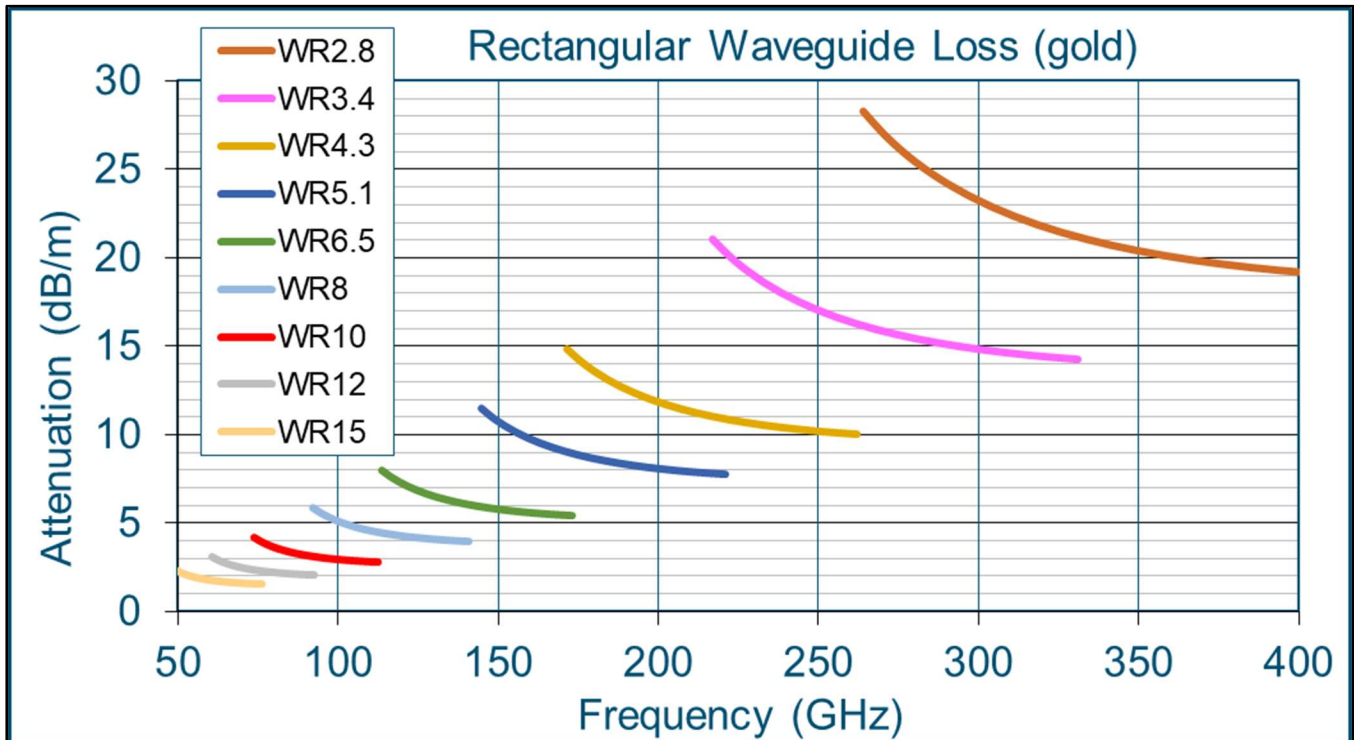

Anti-Cocking Round Waveguide Flanges

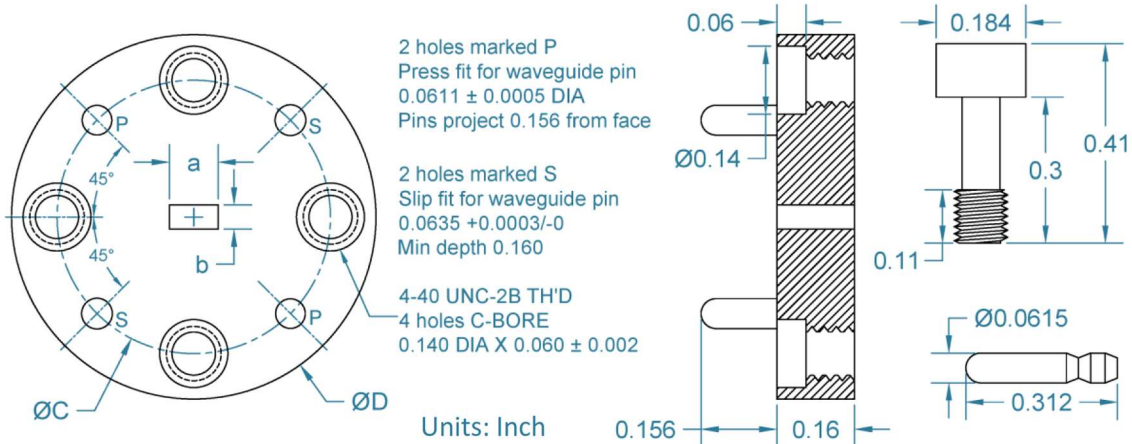

| WR- | 22 | 19 | 15 | 12 | 10 | 8 | 6.5 | 5.1 | 4.3 | 3.4 | 2.8 |
|-----|----------|----------|----------|----------|-----------|-----------|------------|------------|------------|------------|------------|
| GHz | 33 50 | 40 60 | 50 75 | 60 90 | 75 110 | 90 140 | 110 170 | 140 220 | 170 260 | 220 330 | 260 400 |
| a | .224 | .188 | .148 | .122 | .100 | .080 | .065 | .051 | .043 | .034 | .028 |
| b | .122 | .094 | .074 | .061 | .050 | .040 | .0325 | .0255 | .0215 | .017 | .014 |
| φC | .9375 | | | .5625 | | | | | | | |
| φD | 1.125 | | | .750 | | | | | | | |

Square Waveguide Flanges

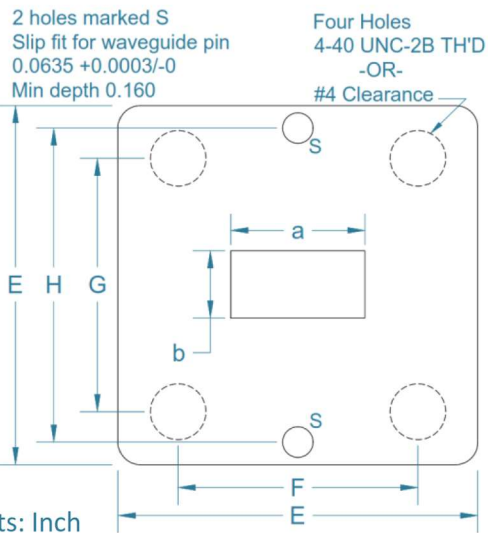

| WR | a | b | E | F | G | H |
|----|------|------|------|------|------|-------|
| 42 | .420 | .170 | .875 | .640 | .670 | .7500 |
| 28 | .280 | .140 | | | | |
| 22 | .224 | .122 | .750 | .500 | .530 | .6562 |
| 19 | .188 | .094 | | | | |

Cap-Head Screws

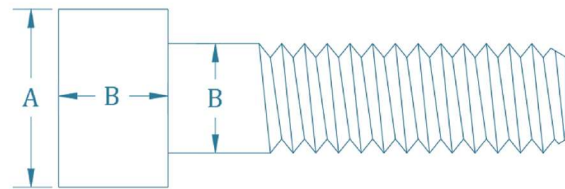

| Size | Thread /inch | Head Dia. A | Body Dia. B | Tap Drill | Counter bore (inch) | Clearance Hole Close/Free |
|------|--------------|-------------|-------------|-----------|---------------------|---------------------------|
| #0 | 80 | .096 | .060 | 3/64 | 1/8 | .0635/.070 |
| #1 | 72 | .118 | .073 | #53 | 5/32 | .076/.081 |
| #2 | 56 | .140 | .086 | #50 | 3/16 | .089/.096 |
| #4 | 40 | .183 | .112 | #43 | 7/32 | .116/.1285 |
| #6 | 32 | .226 | .138 | #36 | 9/32 | .114/.1495 |
| #8 | 32 | .270 | .164 | #29 | 5/16 | .1695/.177 |
| #10 | 24 | .312 | .190 | #25 | 3/8 | .196/.201 |
| 1/4 | 20 | .375 | .250 | #7 | 7/16 | .257/.266 |

Rectangular Waveguide Chart

| EIA WR- (##) | RCSC WG- (##) | IEEE WM- (####) | Band | Internal Dimension (mil) | Standard Frequency (GHz) | fc TE10 (GHz) | fc TE20 (GHz) | UG- (###/#) |
|--------------|---------------|-----------------|------|--------------------------|--------------------------|---------------|---------------|-------------|
| 42 | 20 | | K | 420 x 170 | 17.5 - 26.5 | 14.1 | 28.2 | |
| 34 | 21 | | | 340 x 170 | 22.0 - 33.0 | 17.4 | 34.8 | |
| 28 | 22 | | Ka | 280 x 140 | 26.5 - 40.0 | 21.1 | 42.2 | 599/U |
| 22 | 23 | | Q | 224 x 112 | 33.0 - 50.5 | 26.3 | 52.6 | 383/U |
| 19 | 24 | | U | 188 x 94 | 40.0 - 60.0 | 31.4 | 62.8 | 383/UM |
| 15 | 25 | | V | 148 x 74 | 50.5 - 75.0 | 39.9 | 79.8 | 385/U |
| 12 | 26 | | E | 122 x 61 | 60 - 90 | 48.4 | 96.8 | 387/U |
| 10 | 27 | 2540 | W | 100 x 50 | 75 - 110 | 59 | 118 | 387/UM |
| 8 | 28 | 2032 | F | 80 x 40 | 90 - 140 | 73.8 | 147.6 | 387/UM |
| 6.5 | 29 | 1651 | D | 65 x 32.5 | 110 - 170 | 90.8 | 181.6 | 387/UM |
| 5.1 | 30 | 1295 | G | 51 x 25.5 | 140 - 220 | 116 | 232 | 387/UM |
| 4.3 | 31 | 1092 | Y | 43 x 21.5 | 170 - 260 | 137 | 274 | 387/UM |
| 3.4 | 32 | 864 | J | 34 x 17 | 220 - 330 | 174 | 348 | 387/UM |
| 2.8 | | 710 | | 28 x 14 | 260 - 400 | 211 | 422 | 387/UM |
| 2.2 | | 570 | | 22 x 11 | 325 - 500 | 268 | 536 | 387/UM |
| 1.9 | | 470 | | 19 x 9.5 | 400 - 600 | 311 | 622 | 387/UM |
| 1.5 | | 380 | | 15 x 7.5 | 500 - 750 | 393 | 786 | 387/UM |
| 1.2 | | 310 | | 12 x 6 | 600 - 900 | 492 | 984 | 387/UM |
| 1.0 | | 250 | | 10 x 5 | 750 - 1100 | 590 | 1180 | n/a |
| 0.8 | | 200 | | 8 x 4 | 900 - 1400 | 738 | 1476 | n/a |
| 0.65 | | 164 | | 6.5 x 3.25 | 1100 - 1700 | 908 | 1816 | n/a |
| 0.51 | | 130 | | 5.1 x 2.55 | 1400 - 2200 | 1157 | 2314 | n/a |

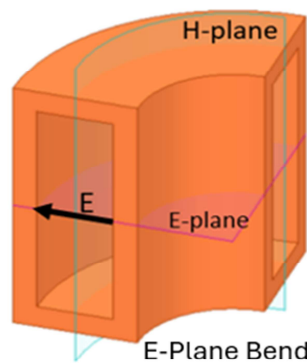
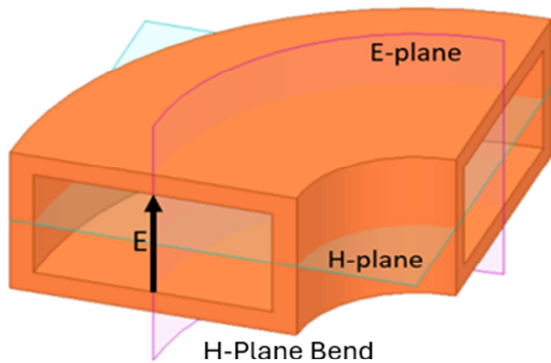

VSWR/|Γ|/RL

| VSWR | Γ | RL (dB) |
|-------|--------|---------|
| 1.065 | 0.0316 | 30 |
| 1.074 | 0.0355 | 29 |
| 1.083 | 0.0398 | 28 |
| 1.094 | 0.0447 | 27 |
| 1.1 | 0.0476 | 26.444 |
| 1.106 | 0.0501 | 26 |
| 1.119 | 0.0562 | 25 |
| 1.135 | 0.0631 | 24 |
| 1.152 | 0.0708 | 23 |
| 1.173 | 0.0794 | 22 |
| 1.196 | 0.0891 | 21 |
| 1.2 | 0.0909 | 20.828 |
| 1.222 | 0.1 | 20 |
| 1.253 | 0.1122 | 19 |
| 1.288 | 0.1259 | 18 |
| 1.3 | 0.1304 | 17.692 |
| 1.329 | 0.1413 | 17 |
| 1.377 | 0.1585 | 16 |
| 1.4 | 0.1667 | 15.563 |
| 1.433 | 0.1778 | 15 |
| 1.499 | 0.1995 | 14 |
| 1.5 | 0.2 | 13.979 |
| 1.577 | 0.2239 | 13 |
| 1.6 | 0.2308 | 12.736 |
| 1.671 | 0.2512 | 12 |
| 1.7 | 0.2593 | 11.725 |
| 1.785 | 0.2818 | 11 |
| 1.8 | 0.2857 | 10.881 |
| 1.9 | 0.3103 | 10.163 |
| 1.925 | 0.3162 | 10 |

$$VSWR = \frac{1 + |\Gamma|}{1 - |\Gamma|}$$

$$RL = -20 \log |\Gamma|$$



Contact form

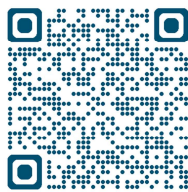

Book a meeting

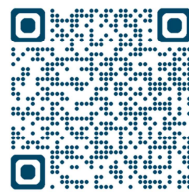

Blog

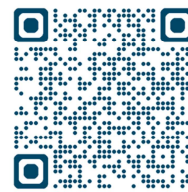

News



Newsletter